

Specification	
Model	LV100W
Capacity	1,000 kgs.
Vertical Travel	750 mm
Minimum Height	83mm
Maximum Height	833mm
Fork Width	685mm
Effective Fork Width	1,080mm
Wheel Diameter - Front	Φ 70mm
Wheel Diameter - Rear	Φ200mm
Control (Operation)	Foot Pedal
Lowering	By pulling Lever
Hyd. Cylinder	Φ40mm X 390mm
Oil (ISO VG32 Hyd.)	0.64 L
Pumping Count (Times)	Approx. 71 Times (with 1,000 kg. Load)
Machine Weight	1,60 kgs.

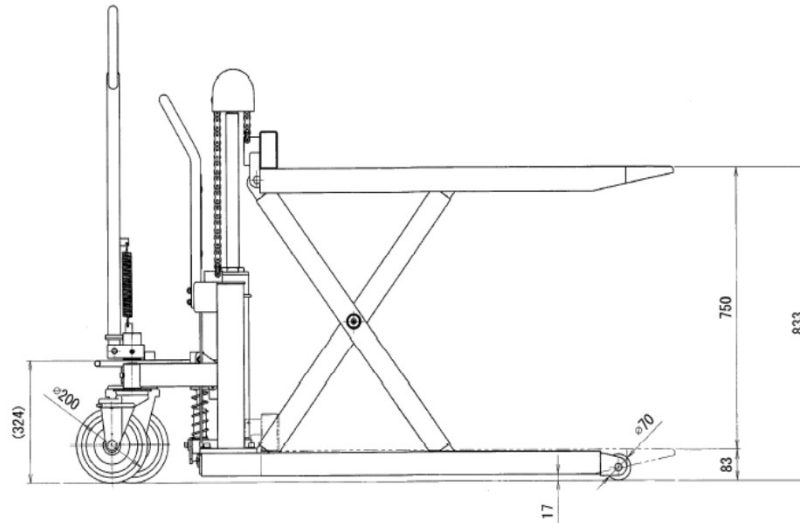
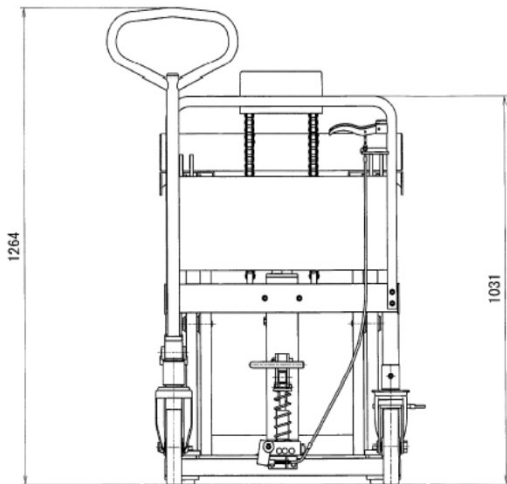
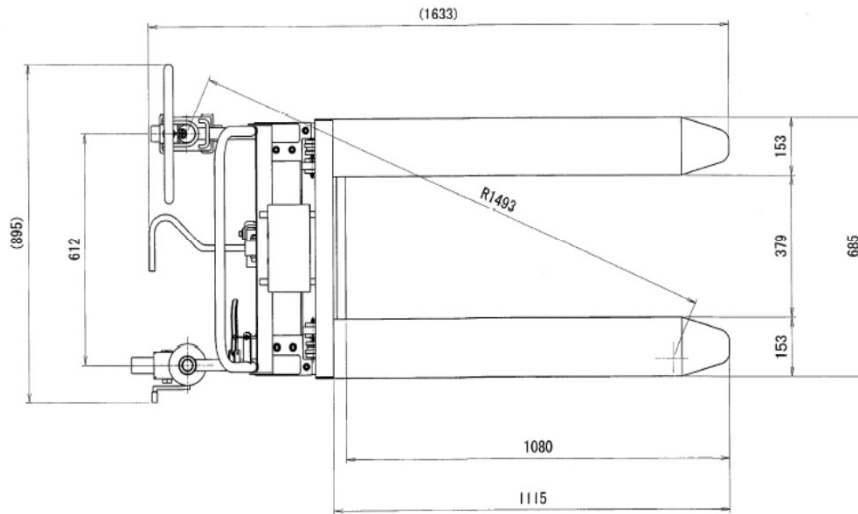

Bishamon  
22/02/24  
T. Niimi

出図  
17.6.30  
技術部

Sugiyasu Corporation	
品名	LV100W Specification Drawing
図番	LV100W -021000-04
日付	2017/06/02
製	石川恵
尺	1:10

承認	年月日	記	専	担当
----	-----	---	---	----